

RL75114-50K

Rocker Column, Stainless Steel Welded-seal, IP67, NTEP Certified 1:10,000 Class III L

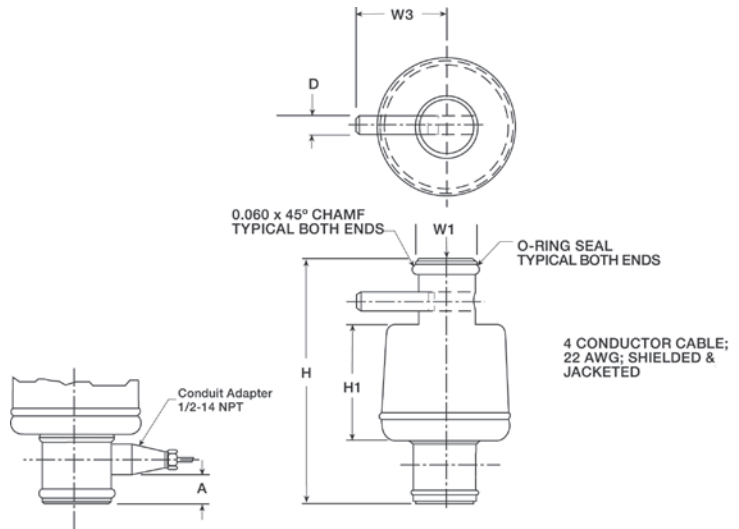

Picture is a representation of actual product



Specifications

Full Scale Output:
1.8 mV/v nominal

Output Resistance:
1,000 (± 10) ohms

Input Resistance:
1,000 ohms

Material/Finish:
Stainless steel

Temperature:
Compensated Range
14°F-104°F/-10°C-40°C
Operating range
-40° F to 150° F/-40° C to 65° C

Safe Overload:
150% full scale

Rated Excitation:
5-10 VDC

Combined Error:
0.025% full scale

Non-repeatability:
0.01% full scale

Insulation Resistance:
1,000 megohms

Seal Type:
Welded Seal IP67

Cable Length:
30 ft (9 m)

Cable Diameter:
0.200 overbraid cable

Cable Color Code:
Green+ Excitation
Black- Excitation
White+ Signal
Red- Signal

Warranty:
Two-year limited warranty

Approvals:

Dimensions

RATED CAPACITY	A	D	H	H1	W1	W3
lb/inches						
50,000 LE*	0.87	0.38	7.56	2.82	1.46	2.18
kg/mm						
22,680.0	15.6	9.7	192.0	71.6	37.08	63.5

Order Information

LOAD RATING	PART #	EST. SHIPPING WEIGHT	PRICE
50,000 lb (22,679.6 kg)	88074	6 lb	Consult
Replacement O-ring	92988	1 lb	Consult
Spring pin	116181	1 lb	Consult

* LE refers to large envelope

Not interchangeable with Sensortronics 65114 - different mV/v

Interchangeable Products

MANUFACTURER	PART #	MODEL
Fairbanks	64166	LCFHR4020-2