

T20

Cella di carico
Load cell

Classe di protezione: IP68	Protection Class: IP68
Alta stabilità a lungo termine	High long term stability
Interamente saldata al LASER	Completely LASER welded
Per applicazioni dinamiche	For dynamic applications

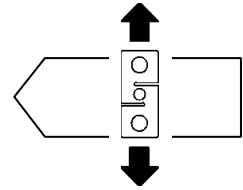

OIML R60 Raccomandazione di riferimento
Reference recommendation

Dimensioni *Dimensions* [mm]



CODE (Class C2)	CODE (Class C3)	LOAD	A	B	ØC	D	E	*F	G
CT205TC25	CT205TC35	5 t	200	45	76	130	35	33	103
CT207T5C25	CT207T5C35	7.5 t							
CT2010TC25	CT2010TC35	10 t							
CT2015TC25	CT2015TC35	15 t	250	54	82	156	47	42.5	109
CT2020TC25	CT2020TC35	20 t							

* Fori di attacco per grilli unificati / Connection holes for standard shackles

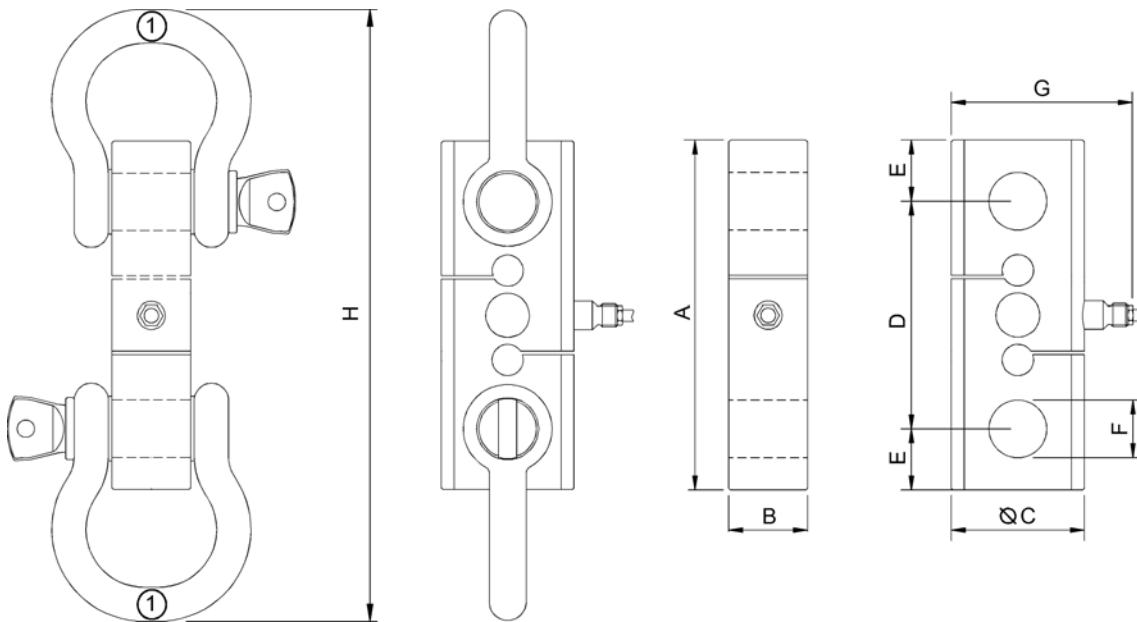

T20:	CODE		ACCESSORIES (optional):	ACCESSORI (opzionali):	H
5, 7.5, 10 t	CGP419.5T	①	Zinc-plated shackles	Grilli zincati	~ 434
15, 20 t	CGP4117T	①	Zinc-plated shackles	Grilli zincati	~ 566

Coefficiente di sicurezza 5.4 / Security coefficient 5.4

Dati Tecnici

Technical Data



CLASSE DI PRECISIONE: OIML R60	ACCURACY CLASS: OIML R60	C2	C3
DIVISIONI LEGALI	LEGAL DIVISIONS	2000	3000
CARICO NOMINALE (E_{max})	NOMINAL LOAD (E_{max})	5 - 7.5 - 10 - 15 - 20 t	
INTERVALLO MINIMO DI VERIFICA (V_{min})	MINIMUM VERIFICATION INTERVAL (V_{min})	$E_{max} / 10000$	
ERRORE COMBINATO NON RIPETIBILITA' RITORNO A ZERO dopo 30 min. CREEP al carico nominale: a) dopo 30 min. b) dopo 20 e 30 min. c) dopo 8 h.	COMBINED ERROR NON REPEATABILITY ZERO RETURN over 30 min. CREEP to nominal load: a) over 30 min. b) over 20 and 30 min. c) over 8 hrs.	$\leq \pm 0.023\%$ $\leq \pm 0.014\%$ $\leq \pm 0.030\%$ $\leq \pm 0.024\%$ $\leq \pm 0.011\%$ $\leq \pm 0.045\%$	$\leq \pm 0.019\%$ $\leq \pm 0.011\%$ $\leq \pm 0.013\%$ $\leq \pm 0.014\%$ $\leq \pm 0.008\%$ $\leq \pm 0.025\%$
EFFETTO DELLA TEMPERATURA (10 °C) a) sullo zero b) sulla sensibilità	TEMPERATURE EFFECT (10 °C) a) on zero b) on sensitivity	$\leq \pm 0.028\%$ $\leq \pm 0.008\%$	$\leq \pm 0.016\%$ $\leq \pm 0.008\%$
SENSIBILITA' NOMINALE TOLLERANZA DI CALIBRAZIONE	NOMINAL SENSITIVITY SENSIVITY TOLERANCE	2mV/V $\leq \pm 0.1\%$	
RESISTENZA DI INGRESSO RESISTENZA DI USCITA RESISTENZA DI ISOLAMENTO BILANCIAMENTO DI ZERO ALIMENTAZIONE DI RIFERIMENTO ALIMENTAZIONE NOMINALE ALIMENTAZIONE MAX.	INPUT RESISTANCE OUTPUT RESISTANCE INSULATION RESISTANCE ZERO BALANCE RECOMMENDED SUPPLY VOLTAGE NOMINAL SUPPLY VOLTAGE RANGE MAXIMUM SUPPLY VOLTAGE	420 \pm 20 Ω 352 \pm 2 Ω > 5 G Ω $\leq \pm 0.5\%$ 10 V 1-15 V 18 V	
VALORI MECCANICI LIMITE riferiti al carico nominale: a) carico minimo b) carico di servizio c) carico limite d) carico di rottura e) massimo carico trasversale f) carico dinamico limite FRECCIA MAX. AL CARICO NOMINALE	MECHANICAL LIMIT values referred to nominal load: a) minimum load b) service load c) max permissible load d) breaking load e) max transverse load f) max permissible dynamic load DISPLACEMENT AT NOMINAL LOAD	0% 120% 150% >300% 200% 50% 0.3 mm	
TEMPERATURA DI RIFERIMENTO CAMPO NOMINALE DI TEMPERATURA TEMPERATURA DI ESERCIZIO TEMPERATURA DI STOCCAGGIO	REFERENCE TEMPERATURE TEMPERATURE NOMINAL RANGE SERVICE TEMPERATURE RANGE STORAGE TEMPERATURE RANGE	+23 °C -10/+40 °C -20/+70 °C -20/+80 °C	
PESO CLASSE DI PROTEZIONE (EN 60529) MATERIALE DELLA CELLA LUNGHEZZA CAVO	WEIGHT PROTECTION CLASS (EN 60529) EXECUTION MATERIAL CABLE LENGTH	4.43 kg 10 kg IP68 (100h at 1m water column) Acciaio Inox / Stainless Steel 5m	

Accelerazione di gravità $g=9.80434 \text{ m/s}^2$ / Acceleration of gravity $g=9.80434 \text{ m/s}^2$

Collegamenti Elettrici Electrical Connections

Cavo schermato PVC 105°C, \varnothing 4.8mm a 4 conduttori \varnothing 0.35mm² stagnati.

PVC 105°C shielded cable, \varnothing 4.8mm with 4 tinned \varnothing 0.35mm² conductors.

Load Cell	OUTPUT	CABLE	CAVO
	EXCITATION+ EXCITATION - OUTPUT+ OUTPUT-	Red Black White Yellow Shield*	Rosso Nero Bianco Giallo Schermo*

* Collegato al corpo della cella di carico. / Connected to the body of the load cell.

AEP transducers



Dasa-Rägister
EN ISO 9001 (2000)
1Q-1100-01

Distributore / Distributor:

41010 Cognento (MODENA) Italy Via Bottego 33/A Tel. 059 346441 Fax. 059 346437

E-mail: aep@aep.it Internet: <http://www.aep.it>

Al fine di migliorare le prestazioni tecniche del prodotto, la società si riserva di apportare variazioni senza preavviso.
In order to improve the technical performances of the product, the company reserves the right to make any change without notice.