

SPI PLATFORM HIGH CAPACITY SCALE LOAD CELL (U.S. & METRIC)

FEATURES & BENEFITS

- Capacities: 25, 50, 100, 150 lbf (111, 222, 445, 667 N)
- Proprietary Interface temperature compensated strain gages
- 0.01% non-repeatability
- Safe overload to 200%
- 0.0008%/°F temp. effect on output
- Eccentric load compensated

SPECIFICATIONS

ACCURACY – (MAX ERROR)				
Nonlinearity – %FS		±0.02		
Hysteresis – %FS		±0.02		
Non-repeatability – %RO		±0.01		
Creep, in 20 min – %		±0.025		
Eccentric load sensitivity – % / in		0.012		
TEMPERATURE				
Compensated Range	°F	+15 to +115		
	°C	-10 to +45		
Operating Range	°F	-65 to +200		
	°C	-55 to +90		
Effect on Output – % / °F MAX		±0.0008		
Effect on Zero – %RO / °F MAX		±0.0015		
ELECTRICAL				
Rated Output – mV/V (Nominal)		3.0		
Zero Balance – %RO		±5.0		
Bridge Resistance – Ohm (Nominal)		350		
Excitation Voltage – VDC MAX		15		
Insulation Resistance – Megohm		5000		
MECHANICAL				
Calibration		Compression		
Safe Overload – %CAP		200		
NATURAL FREQUENCY/DEFLECTION				
lbf	N	Deflection		Nat. Freq. – Hertz
		in	mm	
25	111	0.008	0.20	240
50	222	0.008	0.20	310
100	445	0.007	0.18	470
150	667	0.005	0.13	580
Material		Aluminum		

STANDARD CONFIGURATION



Model SPI (Shown)

OPTIONS

- Cable length
- Standardized output
- Transducer Electronic Data Sheet (TEDS)
- Special temperature range
- Add connector to cable

ACCESSORIES

- Instrumentation

CONNECTOR OPTIONS

- 5 ft (1.5 m) integral cable

* Consult factory for more technical information.

Metric dimensions and capacities are provided for conversion only. Standard product will be sold in lbf and U.S. dimensions. Metric capacities available upon special request and at an additional cost.

SPI PLATFORM HIGH CAPACITY SCALE LOAD CELL (U.S. & METRIC)

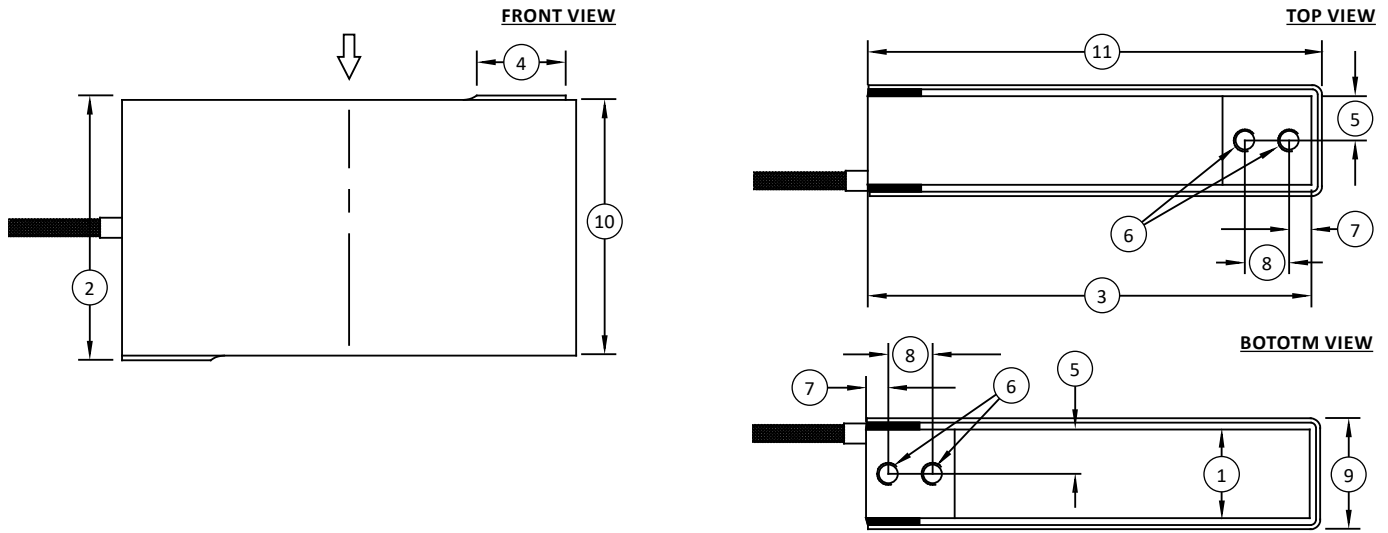

DIMENSIONS

See Drawing	CAPACITY			
	U.S. (lbf)	Metric (N)	U.S. (lbf)	Metric (N)
	25, 50	111, 222	100, 150	445, 667
	in	mm	in	mm
(1)	1.00	25.4	1.00	25.4
(2)	3.00	76.2	3.00	76.2
(3)	5.00	127	6.00	152.4
(4)	1.00	25.4	1.50	38.1
(5)	0.50	12.7	0.50	12.7
(6)	¼-28 UNF-2B ↓ 0.56	¼-28 UNF-2B ↓ 14.2	¼-28 UNF-2B ↓ 0.56	¼-28 UNF-2B ↓ 14.2
(7)	0.25	6.4	0.25	6.4
(8)	0.50	12.7	1.00	25.4
(9)	1.25	31.8	1.25	31.8
(10)	2.88	73.0	2.88	73.0
(11)	5.12	130	6.12	155.4