

**Interchangeable Products**

- VPG SENSORTRONICS®  
**65058A**..... page 327
- VPG CELTRON®  
**CLB**..... page 198

**Weigh Module Available**

- RICE LAKE WEIGHING SYSTEMS  
**2100HE**..... page 40
- RICE LAKE WEIGHING SYSTEMS  
**MVS**..... page 98

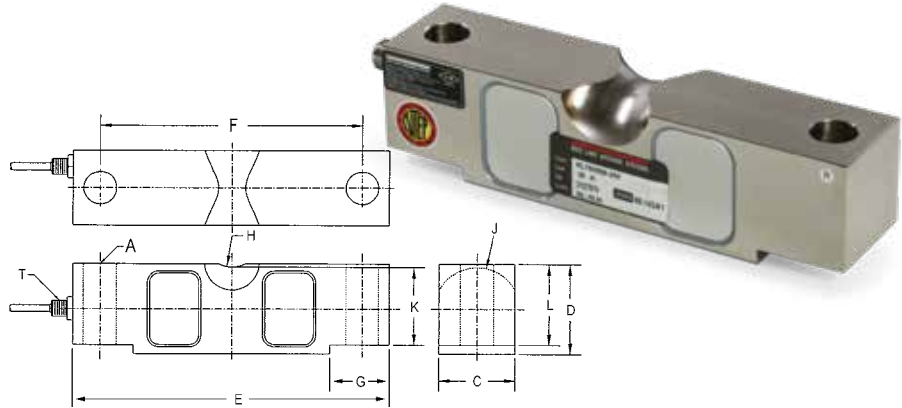

**Specifications**

- Full Scale Output:**  
3.0 mV/V
- Output Resistance:**  
700 (± 5) ohms
- Input Resistance:**  
770 (± 10) ohms
- Material/Finish:**  
High-alloy steel, nickel plated
- Temperature:**  
Compensated range  
14° F to 104° F/-10° C to 40° C  
Operating range  
-40° F to 150° F/-40° C to 65° C

- Safe Overload:**  
150% full scale
- Safe Sideload:**  
100% full scale
- Rated Excitation:**  
5-10 VDC (15 V maximum)
- Nonlinearity:**  
0.03% full scale
- Hysteresis:**  
0.02% full scale
- Insulation Resistance:**  
5,000 megohms

- Seal Type:**  
Environmentally sealed, IP67
- Cable Length:**  
35 ft (10.6 m)
- Cable Diameter:**  
0.200 polyurethane jacket 10,000 lb-25,000 lb  
0.305 polyurethane jacket 40,000 lb-125,000 lb
- Cable Coloring:**  
Red .....+ Excitation  
Black.....- Excitation  
Green.....+ Signal  
White .....- Signal

- Warranty:**  
Two-year limited warranty

**Approvals:**



**Dimensions**

Picture is a representation of actual product

Rated Capacity	A	C	D	E	F	G	H	J	K	L	T
<b>lb/in</b>											
10,000-25,000	0.68	1.69	1.94	7.75	6.50	1.38	0.75	0.90	1.63	1.70	1/4-18NPT
40,000	0.81	1.94	2.44	10.25	8.50	1.93	1.00	1.12	2.00	2.10	1/4-18NPT
50,000-75,000	1.06	2.44	2.94	10.25	8.50	1.93	1.00	1.37	2.54	2.65	1/2-14NPT
100,000-125,000	1.62	2.90	3.86	15.25	12.75	3.13	1.50	1.80	3.30	3.43	1/2-14NPT
<b>kg/mm</b>											
4,536.1-11,339.8	17.3	42.9	49.3	196.9	165.1	35.1	19.1	22.9	41.4	43.2	1/4-18NPT
18,143.7	20.6	49.3	62.00	260.4	215.9	49.00	25.4	28.5	50.8	53.3	1/4-18NPT
22,679.6-34,019.4	26.9	62.00	74.7	260.4	215.9	49.00	25.4	34.8	64.5	67.3	1/2-14NPT
45,359.4-56,699.1	41.2	737.00	980	387.4	323.9	79.5	38.1	45.7	83.8	87.1	1/2-14NPT

**Order Information**

Load Rating	Part#	Est. Weight	Price
<b>NTEP Certified 1:10,000</b>			
20,000 lb	34314	8 lb	Consult
25,000 lb	34315	8 lb	Consult
40,000 lb	34316	13 lb	Consult
50,000 lb	34317	19 lb	Consult
60,000 lb	34318	19 lb	Consult
75,000 lb	34319	19 lb	Consult
100,000 lb	34320	40 lb	Consult
125,000 lb	34321	40 lb	Consult
<b>Non-NTEP Certified</b>			
10,000 lb	41890		Consult
<b>60 ft Cables</b>			
50,000 lb	53417	20 lb	Consult
75,000 lb**	39516	20 lb	Consult
75,000 lb*	73839	20 lb	Consult
125,000 lb	96944	40 lb	Consult
<b>100 ft Cable</b>			
75,000 lb	74725	22 lb	Consult

\*Stainless steel overbraid cable  
\*\*Used in Rice Lake truck scales

**Replacement Load Cells for RL75058 Class III Rice Lake Coil Scale**

Load Rating	Part #	Est. Weight	Price
20,000 lb	121439	8 lb	Consult
25,000 lb	121440	8 lb	Consult
40,000 lb	121441	13 lb	Consult
50,000 lb	121442	19 lb	Consult
60,000 lb	121443	19 lb	Consult
75,000 lb	121444	19 lb	Consult