

RLSP4

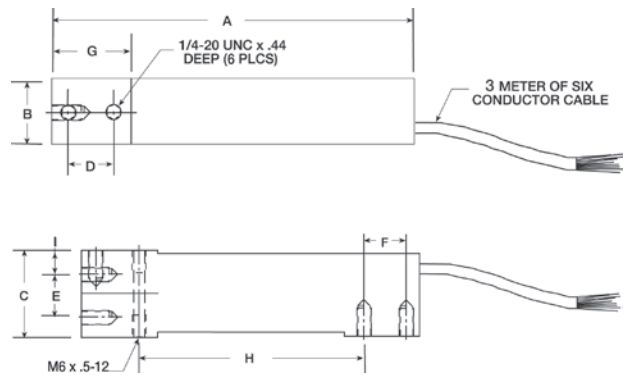

Single Point, Aluminum NTEP Certified 1:5000 Class III Single Cell



Picture is a representation of actual product



Specifications

Full Scale Output: 2.0 mV/V	Safe Overload: 150% full scale	Cable Length: 3.1 m (10 ft)	Max Platform Size: 3 kg-10 kg (12 in x 12 in) 15 kg-30 kg (18 in x 18 in) 50 kg-100 kg (24 in x 24 in)
Output Resistance: 350 (± 3) ohms	Rated Excitation: 5-10 VDC (15 V maximum)	Cable Diameter: 0.19/PVC jacket	Warranty: Two-year limited warranty
Input Resistance: 350 ohms	Combined Error: 0.02% full scale	Cable Color Code: Green + Excitation Black - Excitation Blue + Sense Brown - Sense Red + Signal White - Signal Yellow Shield	Approvals:   
Material/Finish: Anodized aluminum	Insulation Resistance: 5,000 megohms		
Temperature: Compensated range 14°F to 104°F/-10°C to 40°C Operating range -40°F to 150°F/-40°C to 65°C	Deflection at Capacity: 5 kg-100 kg=0.4 mm (0.015 in)		
	Seal Type: Environmentally sealed		

Dimensions

RATED CAPACITY	A	B	C	D	E	F	G	H	I
lb/inches									
11.0-220.5	5.92	1.00	1.57	0.75	0.75	0.75	1.33	3.92	0.45
kg/mm									
5-100	150.3	25.4	39.9	19.1	19.1	19.1	33.8	99.6	11.4

Order Information

LOAD RATING		PART #	EST. SHIPPING WEIGHT	PRICE
5 kg*	(11.0 lb)	91724	2 lb	Consult
7 kg	(15.4 lb)	91725	2 lb	Consult
10 kg	(22.1 lb)	91726	2 lb	Consult
15 kg	(33.1 lb)	91727	2 lb	Consult
20 kg	(44.1 lb)	91728	2 lb	Consult
30 kg	(66.2 lb)	91729	2 lb	Consult
50 kg	(110.3 lb)	91730	2 lb	Consult
75 kg	(165.3 lb)	91731	2 lb	Consult
100 kg	(220.5 lb)	91732	2 lb	Consult

*Non-NTEP Certified

Interchangeable Products

MANUFACTURER	MODEL	PAGE #
HBM®	SP4	251