

# RL1380

Single Point, Stainless Steel NTEP Certified 1:3000 Class III Single Cell, IP67

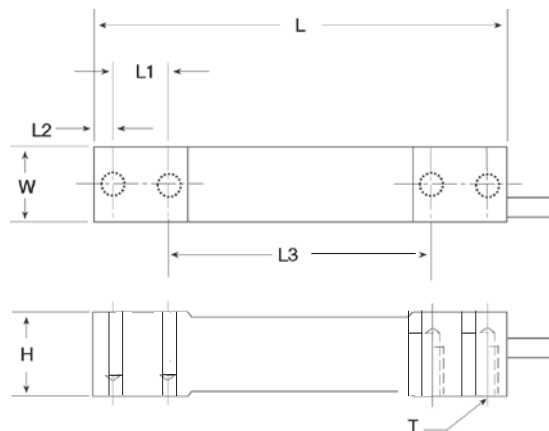

Picture is a representation of actual product



## Specifications

<b>Full Scale Output:</b> 2.0 mV/V	<b>Safe Overload:</b> 150% full scale	<b>Cable Length:</b> 3.1 m (10 ft)	<b>Max Platform Size:</b> 15.75 in x 15.75 in
<b>Output Resistance:</b> 350 (± 3) ohms	<b>Rated Excitation:</b> 5-10VDC (15V maximum)	<b>Cable Diameter:</b> 0.190 polyurethane jacket	<b>Warranty:</b> Two-year limited warranty
<b>Input Resistance:</b> 350 ohms	<b>Combined Error:</b> 0.03% full scale	<b>Cable Color Code:</b> Green ..... + Excitation Black ..... - Excitation White ..... + Signal Red ..... - Signal Yellow ..... Shield	<b>Approvals:</b> 
<b>Material/Finish:</b> Stainless steel	<b>Insulation Resistance:</b> 1,000 megohms	<b>Deflection:</b> <0.4 mm Full scale	
<b>Temperature:</b> Compensated range 14°F to 104°F/-10°C to 40°C Operating range -40° F to 150° F/-40° C to 65° C	<b>Seal Type:</b> Environmentally sealed, IP67		

## Dimensions

RATED CAPACITY	W	L	L1	L2	L3	T	H
<b>lb/inches</b>							
15.4-33.1	0.75	5.50	0.75	0.25	3.50	1/4-20 UNC	1.19
66.1-132.3	0.94	5.50	0.75	0.25	3.50	1/4-20 UNC	1.19
<b>kg/mm</b>							
7-15	19.1	139.7	19.1	6.4	88.9	1/4-20 UNC	30.2
30-60	23.9	139.7	19.1	6.4	88.9	1/4-20 UNC	30.2

## Order Information

LOAD RATING	PART #	EST. SHIPPING WEIGHT	PRICE
7 kg (15.4 lb)	30783	2 lb	Consult
10 kg (22.0 lb)	30782	2 lb	Consult
15 kg (33.1 lb)	30781	2 lb	Consult
30 kg (66.1 lb)	30780	2 lb	Consult
60 kg (132.3 lb)	30779	2 lb	Consult

## Interchangeable Products

MANUFACTURER	MODEL	PAGE #
HBM®	PWS	256